

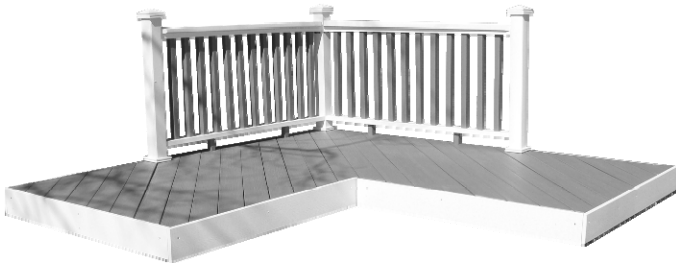

# INSTALLATION INFORMATION

## Decking Installation Guidelines



Please note that Lumberock® Premium Decking claims no liability or responsibility for the improper installation of our product. All installations are unique and it is the sole responsibility of the installer to determine specific requirements in regard to each application. We recommend that all designs be reviewed by a licensed architect, engineer or local building official before installation.

### Framing and Joist Span

The frame of a deck is its primary support structure, consisting of posts, beams and joists. Follow these deck framing guidelines before installing Lumberock®. All joists must be level and structurally sound for new and existing deck frames.

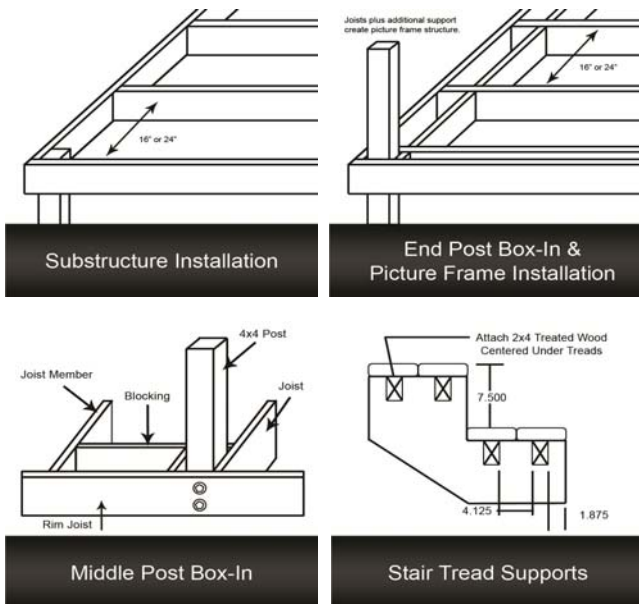

Use the following table to determine the appropriate joist span for your residential or commercial project. Deck boards may be placed perpendicular to the joist or placed diagonally on the joist. Remember to install Lumberock® board with the wood grain pattern facing up.

### Maximum Joist Framing Span On-Centers

		RESIDENTIAL		COMMERCIAL	
		90° Perpendicular	45° Diagonal	90° Perpendicular	45° Diagonal
BOARD PROFILE	5/4 x 6 Boards	16"	12"	12"	12"
	2 x 6 Boards	24"	16"	16"	16"

Joist framing span applies to Standard, Groove & Groove and Tongue & Groove profiles.

### Gapping and Thermal Expansion

Lumberock® boards are gapped end-to-end, end-to-trim or end-to-house based on their location within your project. Proper gapping is necessary to accommodate a small amount of thermal expansion that is common to all plastic lumber materials. Lumberock® boards do not need to be gapped side-by-side. The amount of expansion/contraction that occurs will depend on the length *and* temperature of the board at the time of installation. The most significant changes in the length of the board will occur when you are working in extreme temperatures. High altitudes will also increase these estimated expansion numbers.

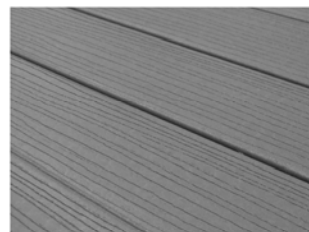

Side-by-Side = No Gapping



End-to-End or End-to-Trim = Gap according to estimated expansion table.

For more information about Lumberock® Mineral Plastic Composite Decking visit [www.lumberock.com](http://www.lumberock.com)



# INSTALLATION INFORMATION

You can expect that a 12-foot board installed at 60°F will expand 1/8" on each end of the board. Therefore, an end-to-trim or end-to-house gap will be 1/8", while two boards placed end-to-end will require a 1/4" gap. Keep in mind that boards kept in direct sunlight will be warmer than boards stacked underneath. This chart based on climates where maximum temperature is 100°F. To account for end-to-end expansion, simply double these gap values.

## Estimated End-to-Trim Expansion

Board Length	Installed Temperature						Decimal Conversion	
	Feet	End Gap to leave for expansion in inches						
		0	20	40	60	80		
6	0.17	0.14	0.10	0.07	0.03	0.00	1/8	0.13
8	0.23	0.18	0.14	0.09	0.05	0.00	3/16	0.19
12	0.34	0.27	0.2	0.14	0.07	0.00	1/4	0.25
16	0.45	0.36	0.27	0.18	0.09	0.00	5/16	0.31
							3/8	0.38
							7/16	0.44
							9/16	0.56
							11/16	0.69

## Fastening Options

Lumberock® can be installed using a face fastening system or a hidden fastening system. No pre-drilling is necessary to install our recycled plastic lumber, and several color-matching screw options are available. Two screws are needed per joist board. For joist spans of 16" on-centers, 4.5 screws per square foot are needed. For joist spans of 24" on-centers, 3 screws per square foot are needed. This figure does not include trim or railing screws.

Screws that are face fastened are drilled directly down from the deck surface into the wood framing underneath. We recommend stainless steel composite or flat head deck screws (#8 or #10), as these do not leave any material above the surface of the deck. Smaller size deck screws are not recommended. Face fastening is the best choice for wind and/or water up-lift applications.

A hidden fastening system attaches the board to the frame without leaving any marks on the surface of the deck boards. Hidden fasteners are recommended for boards over 16-feet in length to allow the boards to expand and contract with annual temperature changes. Groove and groove profiles are required for hidden fastening systems.

Face Fastening (F.F.): Composite Deck Screws or Flat Head Deck Screws Stainless Steel Screws in #8 or #10 Sizes are Recommended		
Stainless Steel Screw Manufacturers (F.F.)	Size	Length
Simpson Strong-Tie: Swan Secure Swaneze Dexter	#8, #10	2-1/2"
FastenMaster Trapease Composite	#8, #10	2-1/2"
Head Cote Composite Flat Head Composite	#8, #10	2-1/2"
Phillips II Plus Composite	#8, #10	2-1/2"
SplitStop Titan 3 - Star Drive Composite	#8, #10	2-1/2"
Color Matching Composite Deck Screws (F.F.) Length: 2-1/2" to 3" Size: #8 or #10	Lumberock Color Name	Screw Color Name
Simpson Strong-Tie Dexter Composite	Chocolate Brown	Brown
Simpson Strong-Tie Dexter Composite	Cedar	IPF
Headcote Composite & Flat Head	Cedar	Cedar #81
Headcote Composite	Putty	Warm Gray #54
Headcote Composite & Flat Head	Redwood	Brown #34
FastenMaster: Trapease I & II	Redwood	Dark Brown
Hidden Fastening System: EBTY Biscuits	Coverage Area 16" O.C.	Coverage Area 24" O.C.
Stock Number: 175-EBTYS, Gap: 3/32" = .09375"	100/Sq./Feet	175/Sq./Ft.
Stock Number: 175-EBTPV, Gap: 1/8" = .125"	100/Sq./Feet	175/Sq./Ft.
Stock Number: 175-EBTYP, Gap: 3/16" = .1875"	100/Sq./Feet	175/Sq./Ft.
Stock Number: 175-EBTYLC, Gap: 1/4" = .250"	100/Sq./Feet	175/Sq./Ft.

## Trim Board Installation

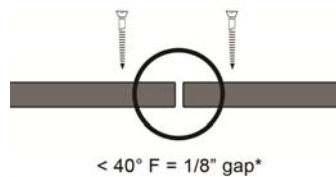

Fascia Installation: Top View



Trim Over

Install Lumberock® 1x10 Trim Boards using two screws every 16" or less. Composite screws (#7, #8 or #10) work best.

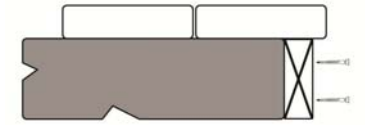

Trim Under